

# A200

Enjoyment through perfection



MAKE IT  
*Wonderful!*

**FRANKE**

# THE ESSENCE OF PERFECTION

For us at Franke, enjoyment means perfect coffee prepared with ease. With the A200, we have created a coffee machine that embodies this perfectly.

The eyes always make the first decision. The haptic experience then confirms the impression: Everything feels valuable and obvious. The operation follows intuitive logic and makes it effortlessly easy to put the A200 into operation. We hear the ceramic grinder, and even these mechanical sounds create confidence. Then the scent of freshly brewed coffee! And the first sip of perfect crema and the rediscovery of an authentic aroma: A Franke from start to finish.



# ENJOYMENT YOU CAN ALWAYS COUNT ON

The A200 was designed so it can be put into service and operated without reading a manual – simply plug in and away you go! This is a masterpiece of Swiss engineering that makes everyday handling of the A200 refreshingly simple.

## Simple yet customizable operation

The A200 invites you to define as many as 36 products and then save them in the menu. In doing so, you first specify how you would like the beverage to be prepared. Should it use the Ethiopian wild coffee from the grinder on the left, or your favorite Ecuadorian arabica from the grinder on the right? Should the brewing period be slightly longer or shorter? Would you like to add a little more or less milk? Then, you then decide in which sequence your beverages are arranged in the menu so that your favorites appear at the very top. The A200 guides you through this configuration with simple, intuitive steps. The process is both simple and customizable.

## An impressive standard of convenience

The qualities of the A200 reveal themselves impressively in everyday professional use. For example, take a look at the A200's cleaning process. Here, the display guides you through the cleaning process using illustrations of the machine and simple prompts. While the detailed instructions show what to do image by image, experienced users can run through the program efficiently in just a few steps. This all takes just a few minutes – without any manual or introduction – and can be carried out without any prior knowledge.



After a product has been selected, you define the desired coffee roasting (left or right grinder, or the powder dosing system).



Total control at a glance with the fill level display and maintenance instructions.



The cleaning process is represented pictorially step by step.

# WELL THOUGHT OUT DOWN TO THE FINEST DETAIL

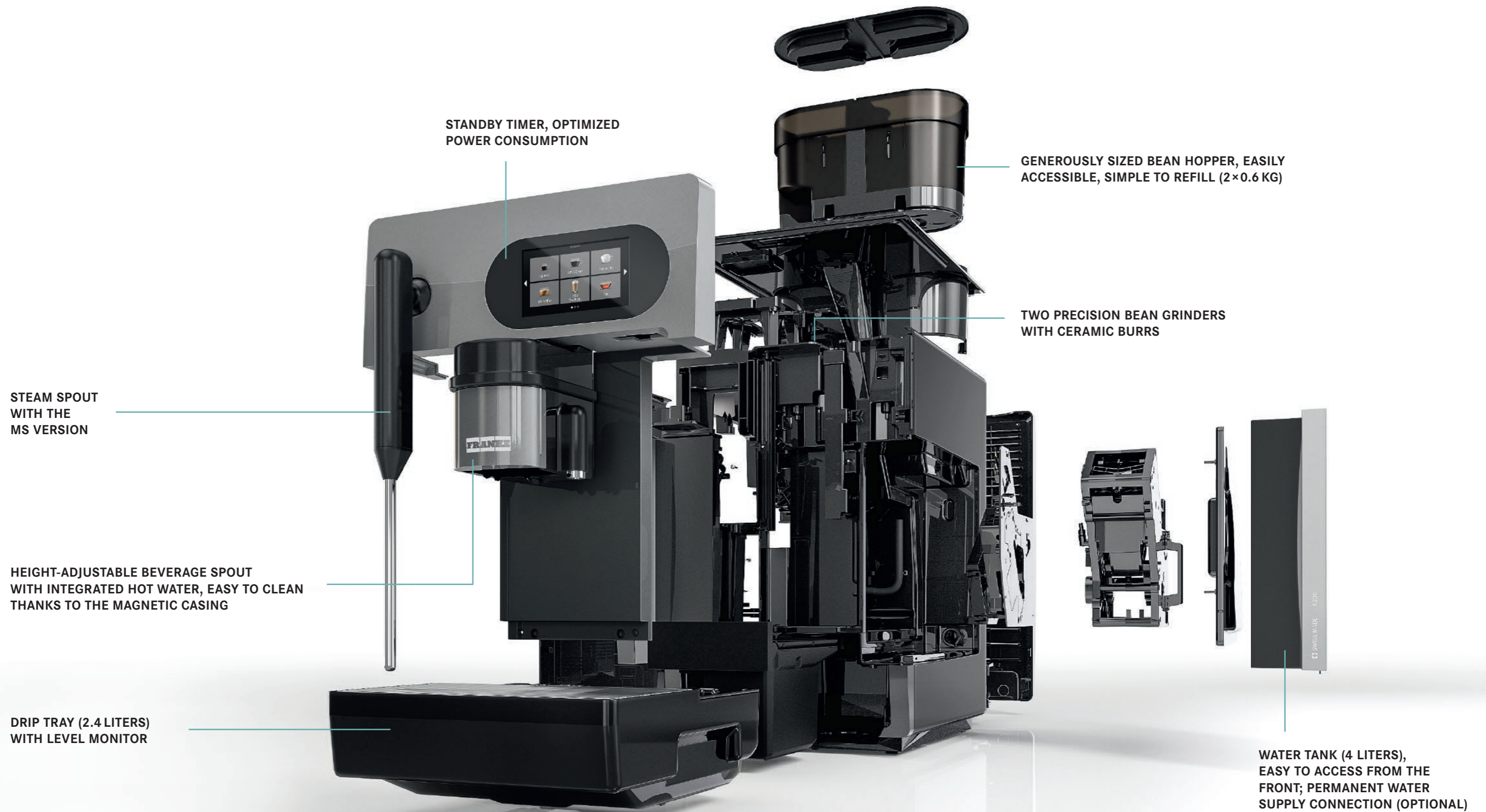

# THE ENGINEERING OF ENJOYMENT

The A200 components work together seamlessly to ensure optimal enjoyment. Every detail has been designed and tested by our developers before being integrated optimally into the overall machine concept.

This starts with the generously sized bean hopper – a feat of engineering all on its own. It is unlocked using the central locking mechanism and simultaneously sealed at the bottom. It can be removed with ease for cleaning or simply refilling with beans. The cover features a silicon sealing rim to protect the refined aroma of the beans and is also available with a lock.

Additionally, the A200 is shipped from the factory with two ceramic bean grinders whose coarseness can be set simply, yet precisely. The two rotary controls are located underneath the bean hopper and are readily accessible and easy to adjust.

The machine's brewing unit is directly accessible from the side and can be removed effortlessly without any tools. This makes cleaning and maintenance a breeze.

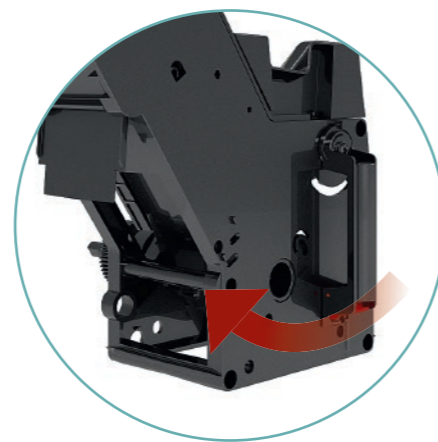

Can be removed with just one turn of the hand



PRECISION BEAN GRINDER WITH LONG-LIFE CERAMIC BURRS

BEAN HOPPER

BREWING UNIT

# SIMPLE HANDLING FOR MAXIMUM CLEANLINESS

Complying with the most stringent hygiene standards is a matter of course for Franke. That's why the A200 now also comes with CleanMaster, the fully automatic cleaning system. Once the cleaning process is started, the milk cleaning sequence is executed automatically from start to finish, and the machine goes into standby mode once it's done. So you can enjoy a spotlessly clean A200 at all times with the greatest of ease.

### An impressive standard of convenience

The A200 boasts an advanced integrated cleaning concept that minimizes your workload and guarantees clean, safe handling. From now on, milk and cleaning agent spills are a thing of the past. Just swap out the milk container for the cleaning container. Choose from the automatic cleaning system EasyClean, which requires the cleaning fluid to be added manually, or CleanMaster, the fully automatic cleaning system with an integrated cleaning cartridge.

### Hygienic, practical milk container system

- Hose-free docking system for the milk container
- Integrated sensor for measuring the effective milk temperature
- Integrated cleaning cartridge

### Efficient cleaning process

- Automated process with integrated cleaning cartridge
- Safe and practical thanks to a separate cleaning container
- Highest level of cleanliness thanks to specially developed milk and coffee cleaning agents
- Maximum convenience: the cleaning process is ended automatically by the machine
- Conforms to HACCP



# ENJOYMENT IS WHEN EVERYTHING IS JUST RIGHT

The A200 will thrill you with countless different possibilities. Enjoy your own beverage creations each and every day at the same high quality, and experience the true meaning of quality at Franke.

#### **Coffee with consistently high barista quality**

- Perfect crema
- Two types of beans for added enjoyment
- Uniform quality in each and every cup

#### **Unique milk foam**

- Manual or automatic foam production
- Individually adjustable foam consistency
- The perfect final touch for any beverage creation

#### **Hot water for tea**

- Programmable filling level
- Also suitable for large cups thanks to the height-adjustable spout



UNIQUE VARIETY!

# EVERYTHING FOR YOUR INDIVIDUAL NEEDS



## MILK SYSTEMS (1)

- FoamMaster™ (FM): hot and cold milk and milk foam, individually adjustable consistency, integrated cleaning system
- Milk system (MS): hot milk and milk foam (KE200)

## CLEANING SYSTEMS (1)

- CleanMaster (CM): fully automatic cleaning system with integrated cleaning cartridge. For outstanding hygiene and unbeatable simplicity, efficiency, and convenience.
- EasyClean (EC): automatic cleaning system with manual addition of the cleaning fluid. Perfect hygiene in just a few steps.

## A200 OPTIONS (2)

- Bean hopper: 2×0.6 kg, lockable
- Permanent water supply connection
- Coffee grounds ejector
- M2M/telemetry
- Accounting system
- Raised feet (40 / 100 mm)

## ACCOUNTING SYSTEM (3)

Can be used for various payment methods, e.g. with coins, card. Ideally suited to public/private vending applications.

## CUP WARMER (4)

With four heatable trays

| PRODUCT SPECIALTIES          | A200 MS EC | A200 FM CM |
|------------------------------|------------|------------|
| Ristretto   Espresso         | ✓          | ✓          |
| Coffee   Café crème          | ✓          | ✓          |
| Cappuccino   Latte macchiato | ✓          | ✓          |
| Hot milk                     | ✓          | ✓          |
| Hot milk foam                | ✓          | ✓          |
| Cold milk                    |            | ✓          |
| Cold milk foam               |            | ✓          |
| Hot water                    | ✓          | ✓          |
| Steam                        | ✓          |            |

SWISS MADE



# FOR COMPLETE FLEXIBILITY

Tailored precisely to your needs.

The following accessories can be combined with the A200:



## REFRIGERATION UNIT SU05 THE ELEGANT SOLUTION

- Refrigeration unit in product design available in 5 l CM, lockable
- Perfect hygiene: intelligent milk hose coupling for contact-free filling
- Fill level alerts via the A200 display
- Top storage surface functions as heatable cup rack, with on/off switch



## KE200 THE MINI MARVEL

- Refrigeration unit (4 l), lockable
- Suitable for small to mid-range capacities



## ACCOUNTING SYSTEM THE MONEY MAESTRO

- Can be used for various payment methods, e.g. with coins, card
- Ideally suited to public/private vending applications
- Can be combined with M2M features

# TECHNICAL DATA FOR A200 WITH ACCESSORIES, PLUS ADDITIONAL COMPATIBLE ACCESSORIES

## MACHINE MODELS

| MODEL                       | POWER   |
|-----------------------------|---|
| A200 MS EC                  | 220-240V 1LNPE 50/60Hz 2.4-2.75kW (13/15/16* A) |
|                             | 220-240V 1LNPE 50/60Hz 1.2-1.5kW (10A)          |
|                             | 220V 1LNPE 50Hz 2.4kW (16A)                     |
|                             | 100V 2LPE 50/60Hz 1.3kW (15A)                   |
| A200 FM CM                  | 220-240V 1LNPE 50/60Hz 2.4-2.75kW (13/15/16* A) |
|                             | 220-240V 1LNPE 50/60Hz 1.2-1.5kW (10A)          |
|                             | 220V 1LNPE 50Hz 2.4kW (16A)                     |
|                             | 100V 2LPE 50/60Hz 1.3kW (15A)                   |
| 120V 2LPE 60Hz 1.45kW (15A) |   |
| Dimensions:                 | 340 mm / 600 mm / 560 mm (W/H/D)                |

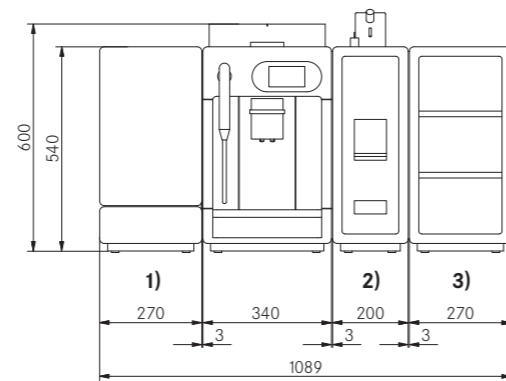

## WATER CONNECTION

|                        |   |
|------------------------|---|
| Fixed water connection | Metal hose with union nut<br>G3/8", L = 1500 mm   |
| Water supply line      | If possible on installation side: untreated water of drinking water quality (not from household decalcification system) |
| Water pressure         | 80 - 800 kPa (0.8 - 8.0 bar)  |
| Total hardness         | 4-8 °dH GH (German total hardness) /<br>7-14 °fH GH (French total hardness) /<br>70-140 ppm (mg/l)                      |
| Carbonate hardness     | 3-6 °dH KH (carbonate hardness) /<br>50-105 ppm (mg/l)  |
| Acid content/pH value  | 6.5-7.5 pH  |
| Chlorine content       | <0.5 mg/l   |

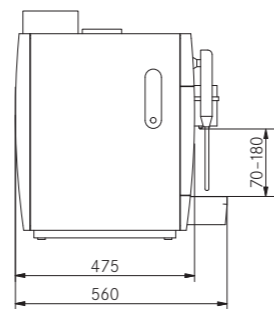

## WATER DRAIN

|            |                           |
|------------|---------------------------|
| Drain hose | Dia. = 16 mm, L = 2000 mm |
|------------|---------------------------|

\*Fuse varies by country

## ACCESSORIES

### 1) REFRIGERATION UNIT SU05 CM (51)

|                        |   |
|------------------------|---|
| Electrical connection: | 220-240V 1LNPE 50/60Hz 1.95-2.3kW (10A)<br>120V 1LNPE 60Hz 1.44kW (15A)<br>220V 1LNPE 50Hz 0.72A (10A)<br>100V 1LNPE 50/60Hz 1.35kW (15A) |
| Dimensions:            | 270 mm / 540 mm / 475 mm (W/H/D)  |
| Weight (empty):        | approx. 24 kg   |
| Compatible with:       | Model A200 FM CM  |

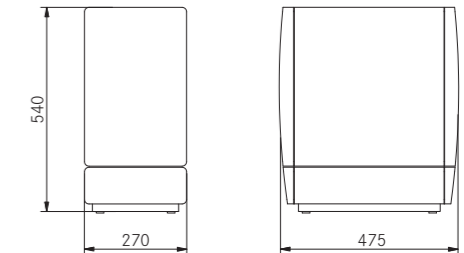

### 2) ACCOUNTING SYSTEM AC

|                        |                                  |
|------------------------|----------------------------------|
| Electrical connection: | 85-264V 1LNPE 50/60Hz (10A)      |
| Dimensions:            | 200 mm / 630 mm / 453 mm (W/H/D) |
| Weight (empty):        | approx. 18 kg                    |
| Compatible with:       | Model A200 MS EC / A200 FM CM    |

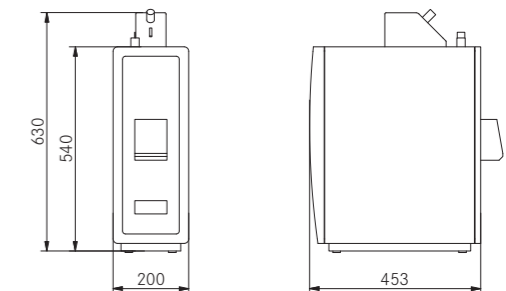

### 3) CUP WARMER CW

|                        |   |
|------------------------|---|
| Electrical connection: | 220-240V 1LNPE 50/60Hz 120W (10A)<br>110V 1LNPE 50/60Hz 80W (10A) |
| Dimensions:            | 270 mm / 540 mm / 454 mm (W/H/D)                                  |
| Weight (empty):        | approx. 20 kg   |
| Compatible with:       | Model A200 MS EC / A200 FM CM                                     |

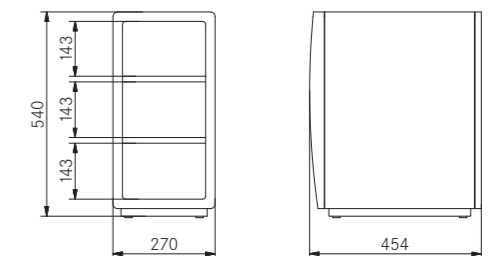

### REFRIGERATION UNIT KE200 (41)

|                        |                                     |
|------------------------|-------------------------------------|
| Electrical connection: | 220-240V 1LNPE 50/60Hz 0.71 A (10A) |
| Dimensions:            | 225 mm / 330 mm / 466.2 mm (W/H/D)  |
| Weight (empty):        | approx. 13 kg                       |
| Compatible with:       | Model A200 MS EC                    |

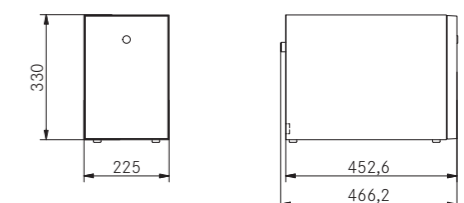



590.0000.06/07.18/CH-EN/Subject to dimensional, design and version changes.

Franke Kaffeemaschinen AG  
Franke-Strasse 9  
4663 Aarburg  
Switzerland  
Phone +41 62 787 31 31  
[www.franke.com](http://www.franke.com)

Franke Coffee Systems GmbH  
Franke Strasse 1  
97947 Grünsfeld  
Germany  
Phone +49 9346 9278 0  
Fax +49 9346 9278 100  
[www.franke.de](http://www.franke.de)

Franke Coffee Systems  
UK Limited  
6A Handley Page Way,  
Old Parkbury Lane,  
Colney Street,  
St Albans,  
Hertfordshire, AL2 2DQ  
England  
Phone +44 1923 635700  
Fax +44 1923 635701  
[www.franke.com](http://www.franke.com)

Franke Coffee Systems  
North America  
800 Aviation Parkway  
Smyrna, TN 37167  
USA  
Phone +1 615 462 4265  
Fax +1 615 462 4400  
[www.franke.com](http://www.franke.com)

